

Hot water tank ELBR

SONNENKRAFT ELBR hot water tanks are the ideal solution for every solar hot water system. Enamel and protective anodes protect these premium quality tanks against corrosion. High-quality insulation - the models up to ELB500R2E have direct expandable foam insulation; ELB750R2E and ELB1000R2E have removable insulation for easier transport - ensures optimal heat insulation. NEW: The ELB200 - 1000R2E-H boiler types are also suitable for "plug-and-flow" installation of the PSKR15 pumping station assembly.

Specifications ELBR

	Unit	ELB160R1E	ELB200R2E	ELB300R2E	ELB400R2E	ELB500R2E	ELB750R2E	ELB1000R2E
Contents	l	160	200	300	400	500	750	1000
Diameter, insulated	mm	560	540	600	700	700	960	960
Diameter, not insulated	mm						790	790
Height, insulated	mm	997	1432	1834	1631	1961	1830	2070
Tilted height	mm	1150	1530	1930	1745	2082	1892	2125
Weight	kg	60	85	120	140	155	195	210
Permissible water pressure	bar	10	10	10	10	10	10	10
Permissible heating pressure	bar	10	10	10	10	10	10	10
Permissible solar loop pressure	bar	10	10	10	10	10	10	10
Permissible operating temp. water	°C	95	95	95	95	95	95	95
Permissible operating temp. heating	°C	110	110	110	110	110	110	110
Permissible operating temp. solar loop	°C	110	110	110	110	110	110	110
Upper heating / reheating register	m ²		0,70	0,81	1,00	1,28	2,00	2,00
Lower heating area / solar register	m ²	0,72	0,95	1,49	1,83	2,11	2,10	2,10
Solar heat exchanger volume	l	5,5	6,4	10,4	12,8	14,7	13,2	13,2
Heating system heat exchanger volume	l		4,8	5,6	6,9	8,9	12,6	12,6
Performance indicator NL top	N _L / kW		2,4 / 25	2,5 / 27	5,7 / 31	8,9 / 40	12 / 59,5	12 / 59,5
Performance indicator NL bottom	N _L / kW	1,4 / 22	4,2 / 31	4,1 / 45	9,4 / 51	16 / 65	35 / 63	37 / 63
Heating flow HV	R		1"	1"	1"	1"	1"	1"
	mm		1146	1488	1354	1604	1500	1778
Heating return HR	R		1"	1"	1"	1"	1"	1"
	mm		786	1120	1006	1114	1095	1373
Solar flow SV ELBR2E/ELBR2E-H	R	3/4" / -	1" / 1"	1" / 1"	1" / 1"	1" / 1"	1" / 1"	1" / 1"
	mm	1032 / -	686 / 687	1028 / 965	895 / 909	940 / 966	690 / 773	690 / 773
Solar return flow SR ELBR2E/ELBR2E-H	R	3/4" / -	1" / 1"	1" / 1"	1" / 1"	1" / 1"	1" / 1"	1" / 1"
	mm	1032 / -	191 / 687	254 / 965	220 / 909	220 / 966	240 / 773	240 / 773
Hot water WW	R	3/4"	3/4"	1"	1"	1"	1 1/4"	1 1/4"
	mm	1032	1366	1725	1523	1855	1600	1880
Cold water KW	R	3/4"	3/4"	1"	1"	1"	1 1/4"	1 1/4"
	mm	1032	55	90	55	55	140	140
Circulation Z	R	3/4"	3/4"	3/4"	3/4"	3/4"	3/4"	3/4"
	mm	1032	899	1243	1111	1264	1207	1485
Sensor thermometer wells	mm	Ø11x600	Ø16x200	Ø16x200	Ø16x200	Ø16x200	Ø16x120	Ø16x120
Heating FH	mm		1011	1353	1223	1409	1320	1598
Solar FS	mm	965	280	403	340	340	467	467
1 1/2" Sleeve for electric heating EHP	mm	965	736	1078	957	1040	880	1100
Thermometer T	mm	1007	1226				1472	1572
Flange F, D _i / TK / D _A	mm	85 / 125 / 150	110 / 150 / 180	110 / 150 / 180	110 / 150 / 180	110 / 150 / 180	110 / 150 / 180	110 / 150 / 180
Anode A1	mm	Ø26x480	Ø26x550	Ø26x1100	Ø26x900	Ø26x1100	1 1/4"xØ33x680	1 1/4"xØ33x680
	mm	top	top	top	top	top	top	top
Anode A2	mm						Ø8xØ33x500	Ø8xØ33x680
	mm						280	280

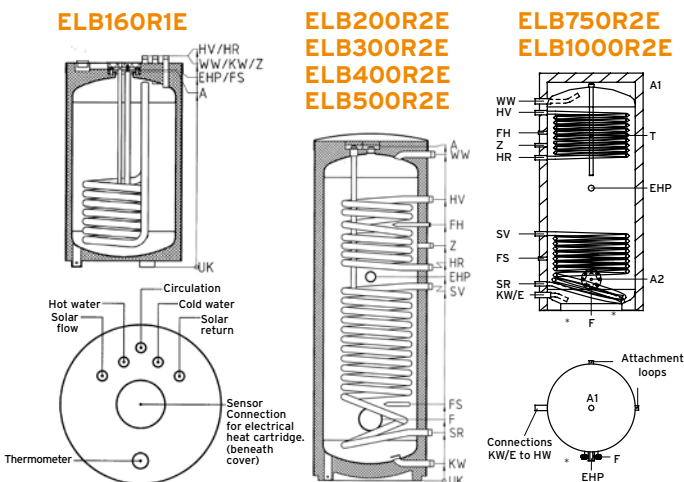

Features of solar hot water tank ELBR

- Large heat exchanger surfaces make tanks ideal for using solar energy
- Smooth pipe register for excellent heat conduction
- Optimum protection against corrosion for a long service life
- Gentle cold water inlet
- Adjustable reheating option
- Pleasing colour coordinated SONNENKRAFT design
- High-quality enamel
- Resistant and attractive shell
- Direct expandable foam insulation up to model ELB500R2E
- High-quality with an optimal fit; and for ease of transport, ELB750R2E and ELB1000R2E have removable insulation

* Top-mounted solar supply and solar recirculation fittings as well as fastening sleeves for "plug-and-flow" installation of the PSKR15 pumping station assembly on the ELBR2E-H
Note: The connection dimensions provided in the technical data table apply to tank ELBR2E. Connection dimensions for ELBR2E-H are slightly different (see manual ELBR2E-H).

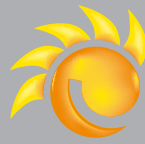

forever clever

SONNENKRAFT®



Backup tanks, hot water tanks

SKL
PSK
PS
ELBR
PSR

FOREVER CLEVER

www.sonnenkraft.com