

SONNENKRAFT™ PS-E TANK

New
improved
version



E³

EASY

Plug & Flow - every part made for easy installation.

EFFICIENT

Most efficient tank to use in large scale solutions.

EXTRA

Patented insulation caps.

PS-E

The new PS-E tank is the optimal solution for storing energy in larger installations. The new fleece insulation contains up to 70% recycled material and reduces the heat losses by 20%. Tanks up to 1000l use the classic and elegant polystyrol surface while the larger tanks are equipped with a flexible foil surface including the easy mountable zip fastener. PS800E/1000E can be connected in parallel with PSC800E/1000E or with PSR800E/1000E.

WHAT IT DOES

The use of PS-E tanks opens a variety of solar system solutions with flexible integration to all heating systems. Below you find one possible chart.

HOW IT WORKS

PS-E tanks in parallel or in series may be used as stand alone solar energy buffers for large(r) systems like multi-family houses, hotels, office buildings, etc. using large fresh water and stratification modules or apartment stations (NWM). On the other hand they can easily extend the buffer volume of PSR-E and PSC-E tanks.

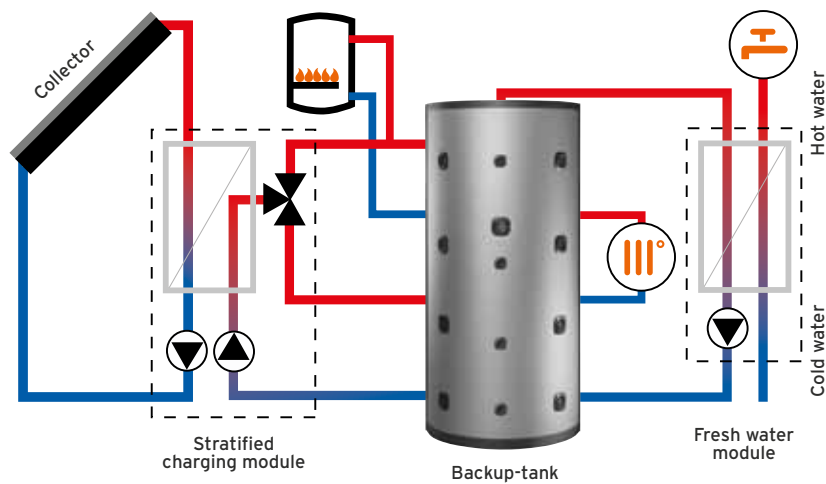

FITS WITH FOLLOWING MODULES:



FWM150/225



SLM120/200



NWM

YOUR BENEFITS AS AN INSTALLER



EASY

Detachable fleece insulation with optimal fit reduces installation and maintenance time.

EFFICIENT

Stabilized temperature zones thanks to horizontal layer plate and flow breaks at return line.

EXTRA

Extended 2" connections for tanks larger than 1500 l.

YOUR BENEFITS AS A CUSTOMER



EASY

Height adjustable feet and bottom cover strip (PS500E - PS1000E).

EFFICIENT

20% heat loss reduction.

EXTRA

Up to 70% recycled material in the fleece insulation.

20% HEAT LOSS REDUCTION

Use of fleece fits perfectly to the surface of the tank, which eliminates chimney effects and provides better insulation of connection hoses. In addition patented insulation caps are helping to reduce heat losses of not used connections.



PERFECT FOR BIG SCALE SOLUTIONS

With the ability to be set up in a parallel installation, the PS-E tank is the best choice for large installations. Also possible are large sized solar systems with only one large tank up to 5000 litres, which reduces the heat losses in comparison to a multi-tank-system.



OPTIMUM SOLAR STRATIFICATION

Stabilized temperature zones thanks to horizontal layer plate and flow breaks at return lines.

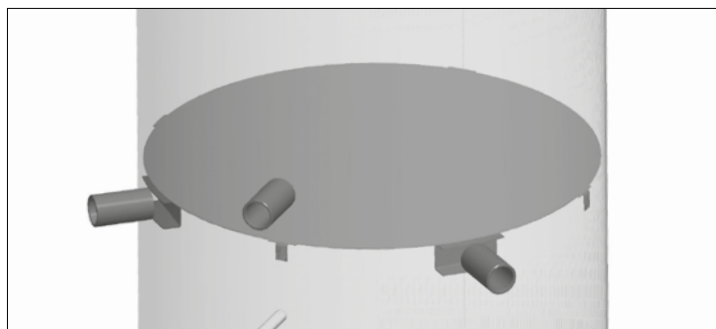

TECHNICAL SPECIFICATIONS

TECHNICAL DATA	UNIT	Ø	PS800E	PS1000E	PS1500E	PS2000E	PS3000E	PS5000E
Art. no.	No.	-	121 433	121 434	121 435	121 436	121 437	121 438
Capacity	l	-	789	920	1425	2006	2670	4967
Diameter, insulated	mm	-	990	990	1200	1300	1490	1840
Diameter, not insulated	mm	-	790	790	1000	1100	1250	1600
Height, insulated	mm	-	1835	2120	2150	2410	2535	2915
Height, not insulated	mm	-	1775	2058	2097	2358	2434	2800
Tilted height (without insulation)	mm	-	1830	2100	2200	2450	2590	3050
Weight (without insulation)	kg	-	121	134	170	245	295	585
Permissible heating pressure	bar	-	3	3	3	3	3	3
Permissible operating temp. heating	°C	-	95	95	95	95	95	95
Sleeve A, 2 x (e.g. hot inlet SLM, boiler flow inlet for hot water)	mm	Rp 6/4"	1450	1780	1760	-	-	-
	mm	Rp 2"	-	-	-	1990	2065	2350
Sleeve B, 2 x (e.g. boiler flow inlet for heating, heating flow outlet)	mm	Rp 6/4"	1030	1250	1350	-	-	-
	mm	Rp 2"	-	-	-	1450	1530	1680
Sleeve C, 2 x (e.g. warm inlet SLM, heating return line)	mm	Rp 6/4"	630	745	825	-	-	-
	mm	Rp 2"	-	-	-	900	825	1070
Sleeve D, 2 x (e.g. return line SLM or FWM, floor heating return line)	mm	Rp 6/4"	260	260	389	-	-	-
	mm	Rp 2"	-	-	-	330	385	500
"VL-FWM Fresh water module forward flow outlet / EL deaeration "	mm	Rp 6/4"	top	top	top	-	-	-
	mm	Rp 2"	-	-	-	top	top	top
FTH1 Sensor immersion sleeve	mm	15x100	1500	1780	1760	2020	-	-
	mm	15x120	-	-	-	-	2075	2350
FTH2 Sensor immersion sleeve	mm	15x100	930	1150	1555	1755	-	-
	mm	15x120	-	-	-	-	1825	2035
FTH3 Sensor immersion sleeve	mm	15x100	560	655	1250	1390	-	-
	mm	15x120	-	-	-	-	1475	1620
FTH4 Sensor immersion sleeve	mm	15x100	260	260	380	330	-	-
	mm	15x120	-	-	-	-	385	500
EHP Sleeve for electric heating	mm	Rp 6/4"	1155	1375	1475	1615	1700	1845

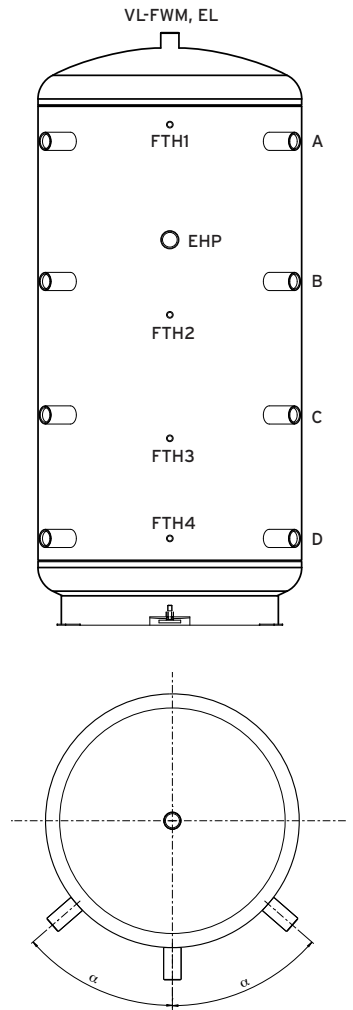

PS800E/PS1000E: $\alpha = 49^\circ$
 PS500E/PS1500-PS5000E: $\alpha = 50^\circ$

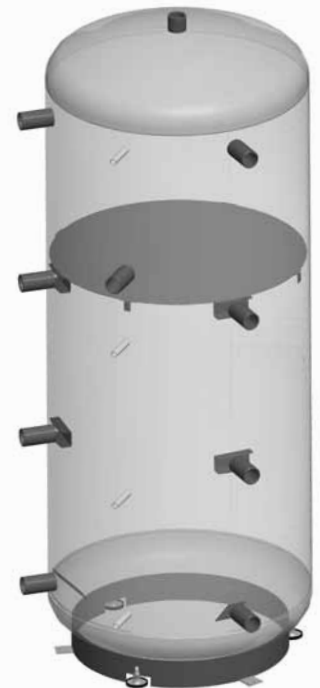

Contact your SONNENKRAFT™ sales representative today.
 The sun will rise again tomorrow.

