

SONNENKRAFT™ PSR-E TANK



EASY

Plug & Flow - every part made for easy installation.

EFFICIENT

Encapsulation of solar register and integrated return line stratification.

EXTRA

Patented insulation caps.

E³

PSR-E

The PSR-E tank can cover up to 30% of your heating and 80% of your hot water demand. It is a part of the COMFORT E solution together with an intelligent fresh water module and a high efficient solar pump station. All developed to fit perfectly together.

WHAT IT DOES

The new PSR-E tank provides a rapid availability of solar energy by a well balanced innovative stratification design. The central buffer tank PSR-E stores the energy coming from the solar system or (when there is no sun) from the backup boiler.

HOW IT WORKS

The PSR-E tank is charged via the high efficient pump unit PSKR18HE. The encapsulated solar register ensures a high efficient and very fast charging of the upper part of the tank where high temperature for the hot water production via the fresh water module FWM15i/30i is needed.

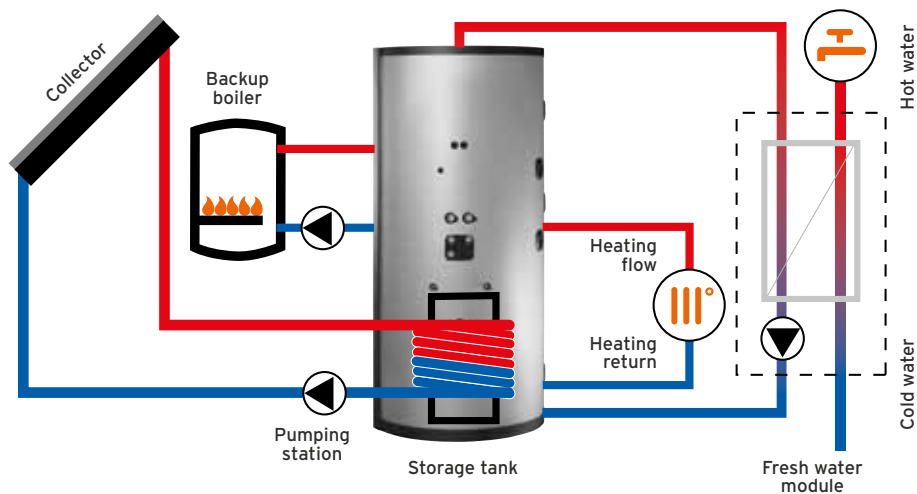

FITS WITH THE FOLLOWING MODULES:

PSKR18HE



FWM15i/30i



YOUR BENEFITS AS AN INSTALLER



EASY

Detachable fleece insulation with optimal fit reduces installation and maintenance time.

EFFICIENT

Encapsulation of solar register enables faster loading and bigger flow breaks improve solar stratification.

EXTRA

Return line stratification raises the solar yield of the system.

YOUR BENEFITS AS A CUSTOMER



EASY

Height adjustable feet and bottom cover strip.

EFFICIENT

20% heat loss reduction.

EXTRA

Sensors hidden behind insulation shell.

20% HEAT LOSS REDUCTION

Use of fleece fits perfectly to the surface of the tank, which eliminates chimney effects and provides better insulation of connection hoses. In addition patented insulation caps are helping to reduce heat losses of not used connections.

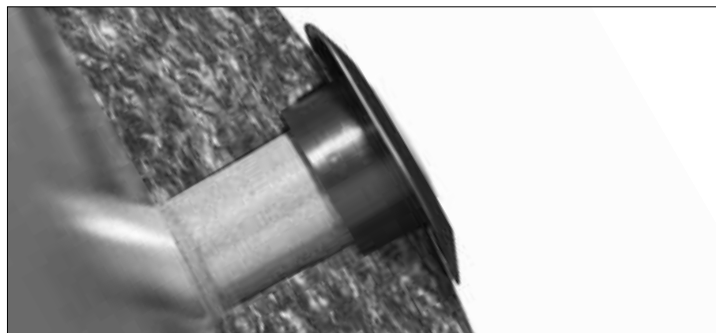

IMPROVED STRATIFICATION

There is an encapsulation of solar register, a faster loading of upper part of tank, which leads to a better use of solar heating support and to an optimal use of the solar yield.



RETURN LINE STRATIFICATION

The integrated return line stratification ensures an increased temperature difference between the top and bottom part of the tank.

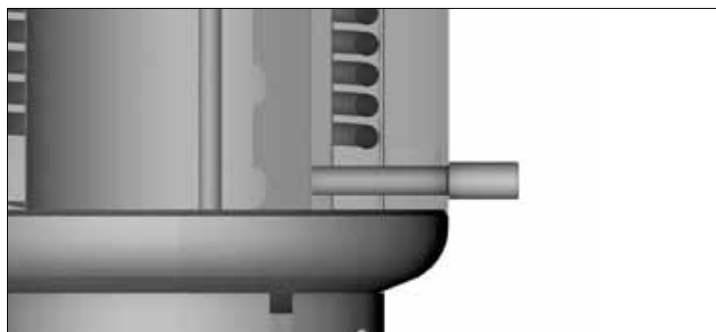

TECHNICAL SPECIFICATIONS

TECHNICAL DATA	UNIT	Ø	PSR500E	PSR800E	PSR1000E
Art. no.	No.	-	121 527	121 528	121 529
Capacity	l	-	500	744	912
Diameter, insulated	mm	-	850	990	990
Diameter, not insulated	mm	-	650	790	790
Height, insulated	mm	-	1720	1780	2135
Height, not insulated	mm	-	1664	1688	2038
Height when tipped, not insulated	mm	-	1710	1740	2080
Weight (without insulation)	kg	-	110	135	160
Permissible heating pressure	bar	-	3	3	3
Permissible solar loop pressure	bar	-	10	10	10
Permissible operating temp. heating	°C	-	95	95	95
Permissible operating temp. solar loop	°C	-	110	110	110
Solar register heating surface area	m ²	-	1,7	2,3	3
Solar register volume	°C	-	11,5	14,6	20
Heat loss according DIN 4753/8 (ΔT 45K), calculated	kWh/d	-	2,9	3,6	3,9
Heat loss rate according EN12977	W/K	-	2,65	3,31	3,59
EL deaeration	mm	Rp 1/2"	top	top	top
Sleeve A (boiler flow inlet for hot water)	mm	Rp 6/4"	1390	1450	1780
"Sleeve B (heating flow outlet, boiler flow inlet for heating or boiler return line for hot water)"	mm	Rp 6/4"	1000	1030	1250
"Sleeve D (heating and floor heating return line, boiler return line for heating, drain)"	mm	Rp 6/4"	220	260	260
Sleeve E (heat pump return line for hot water, electrical heater EHP)	mm	Rp 6/4"	1170	1270	1450
Sleeve F (heating return line for heating without boiler, heat pump return line for heating)	mm	Rp 6/4"	850	870	1050
PSKR18HE solar pumping station - connections					
SV solar flow inlet	mm	G 1"	1010	1030	1210
SR solar return flow	mm	G 1"	1010	1030	1210
FWMi fresh water module - connections					
FWMi-VL forward flow outlet	mm	G 1"	890	910	1090
FWMi-RLM return "middle"	mm	G 1"	812	832	1012
FWMi-RLU return "bottom"	mm	G 1"	890	910	1090
Sensor immersion sleeves					
FWW - sensor clamping plate hot water	mm	-	1350	1350	1575
FH - sensor clamping plate heating	mm	-	1010	1050	1245
FHP - sensor clamping plate heatpump	mm	-	765	805	1000
FS - sensor clamping plate solar	mm	-	500	530	575
Fastening points for modules					
PSKR18HE-BH	mm	2 x M8	1400	1420	1600
FWMi-L/R/U	mm	Bolt/Bolt	627,5	647,5	827,5
FWMi-U	mm	M10	440	460	640

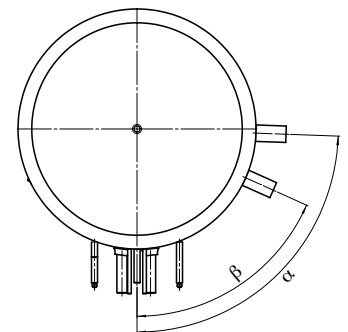
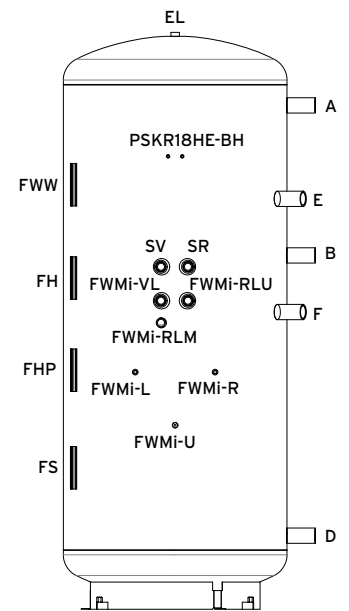

PSR500E: $\alpha = 90^\circ$, $\beta = 68^\circ$
 PSR800E/PSR1000E: $\alpha = 88^\circ$, $\beta = 66^\circ$



Contact your SONNENKRAFT™ sales representative today.
 The sun will rise again tomorrow.

